

Floating Nut Retainer

Product Specification Sheet

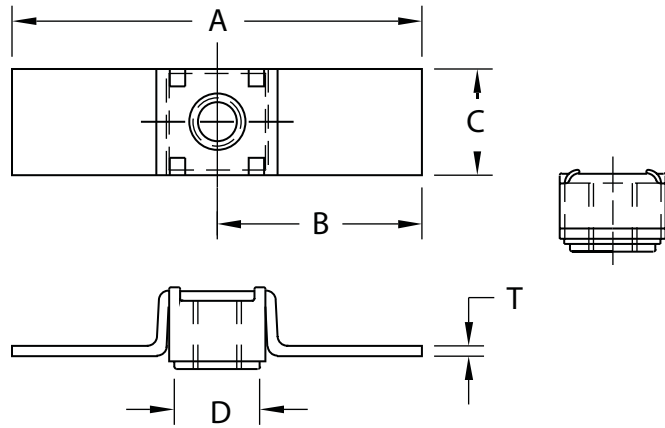

Part Number	Thread Size	A	B	C	D	T
		Length	Half Length	Width	Pilot Diameter	Plate
NR 1420	1/4-20	1.750	0.875	0.562	0.398	0.045 0.050
NR 51618	5/16-18	2.000	1.000	0.781	0.523	0.045 0.050
NR 3816	3/8-16	2.000	1.000	0.781	0.523	0.045 0.050
NR 1213	1/2-13	2.250	1.125	0.937	0.750	0.050 0.060



Sturdy, dependable fasteners referred to as floating nut retainers. The design of this fastener allows the nut to “float” within the steel cage which is ideal for hole misalignment and blind assembly. These nuts are commonly used in fork trucks, rail cars, ocean containers, automobile and office furniture, appliances and numerous other applications.

Material: Retainer: C1008 - C1018 Low Carbon Steel
 Nut: C1008 - C1010 Low Carbon Steel
 Finish: Plain, Unless Specified
 Threads: Unified Standard Class 2B
 ASME B 1.1-2003



Buckeye Fasteners, Inc.

5250 West 164th Street • Brook Park, Ohio 44142-1597

(800) 437-1689 • Fax: (216) 267-3228

buckeyefasteners.com • info@buckeyefasteners.com

© 2012 Buckeye Fasteners, Inc. All Rights Reserved

