

Metric Adjustable Hex Head Leveler

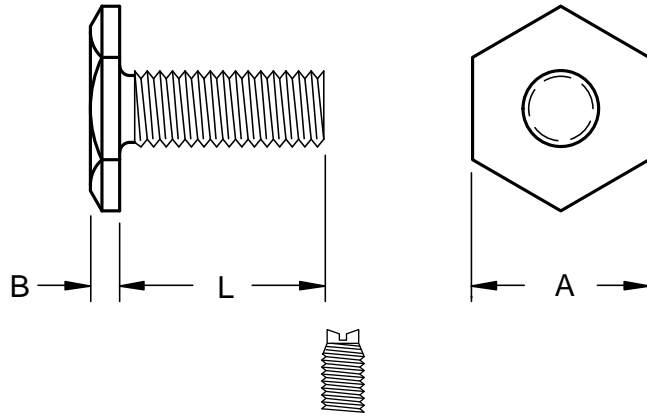

Product Specification Sheet

** FHS • Sizes available with a slotted end for screw driver adjustments.*

Thread Size / Pitch		M6 x 1-6g	M8 x 1.25-6g	M10 x 1.5-6g	M12 x 1.75-6g
Base Across The Flats	A	14.0	19.0	22.0	25.0
Base Thickness	B	2.6	3.2	3.9	4.6
		2.3	2.9	3.6	4.3
Length (Under Head) L Up To 25mm + 0.0 - 0.8	25.0		FHM 08025		
	30.0	FHM 06030			
Over 25mm To 50mm + 0.0 - 1.6	35.0		FHM 08035	FHM 10035	
	40.0		FHS 08040 *	FHS 10040 *	
Over 50mm +0.0 -2.3	60.0			FHM 10060	
	65.0			FHS 10065 *	FHM 12065



The metric FHM leveler is strong, economical and one piece construction. Rolled threads extend full length for maximum adjustment. Exposed base prevents dirt buildup and offers the advantage of easy cleaning. The base is beveled to facilitate moving.

** Easily adjusted with standard wrenches, several sizes are available with a slotted end for screw driver adjustments.*



Material: C1010 High-Welding Quality, Low Carbon Steel
 Finish: Plain, Unless Specified
 Threads: ASME B1.13M-2005

Tensile Strength: 60,000 psi
 Yield Point: 30,000 psi
 Shear Strength: 30,000 psi
 Elongation 2" 30% Max.



Buckeye Fasteners, Inc.

5250 West 164th Street • Brook Park, Ohio 44142-1597

(800) 437-1689 • Fax: (216) 267-3228

buckeyefasteners.com • info@buckeyefasteners.com

© 2007 Buckeye Fasteners, Inc. All Rights Reserved

